

A fluid flow through the sensor causes precise displacement of magnetic piston that acts on a Reed Switch contact.

Technical specifications



Body	PPA (Polyphthalamide)
Spring	AISI 304 stainless steel
Internal clearance	8mm²
Maximum operating pressure	10bar
Operating temperature range	0°C to 100°C 140°C @1h
Inlet/outlet port	G 1/4" female
O'Ring	NBR (nitrilic rubber)
Output connection	Wire 2 x 0.14mm² x 1.5m
Enclosure rating	IP66
Electrical contact	Reed Switch

Operating Voltage	Max. Switching Power	Max. Switching Current	Peak Current
110Vac	20VA	0.2A	0.5A @20ms
220Vac	20VA	0.1A	0.5A @20ms
5Vdc	2.5W	0.5A	1A @20ms
12Vdc	5W	0.5A	1A @20ms
24Vdc*	10W	0.5A	1A @20ms

* If use contactor, RC Snubber Filter KD is required.

Included:

- O'Ring to sealing Parker - code 2-111
- K8 snubber filter to electrical installation (AC)
- Allen wrench to adjust the sensitivity
- Results of the sensitivity test (fixed in the package)

IMPORTANT!

Internal magnetic piston susceptible to retention of ferrous particles.

Installation

- In applications without excessive vibration;
- Vertical mounting with upward flow;
- Minimum distance 20mm from any ferrous surface;
- Mounting with parallel port connection and O'Ring.

Maintenance

1. Open the plug, remove the spring and clean using a brush if there is encrustation;
2. Mount the sensor again as below illustrated;
3. Test the electrical contact using an ohmmeter, moving the magnetic piston.

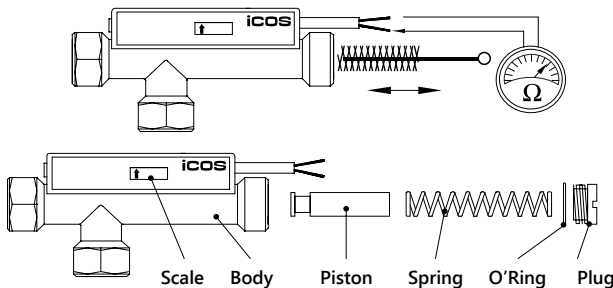

GAS (BSP) Thread: Mounting and Sealing

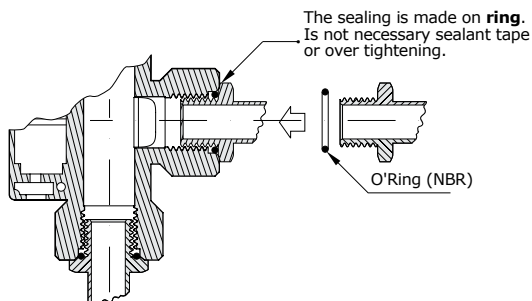

Questions? Call us BEFORE you install: +55 (15) 3032.9190

Term of Warranty

For installations according to this guide: 01 (one) year warranty.
Incorrect installation cancels the warranty - all sensors have been tested and approved.

Liquids with ferrous particles require technical analysis: the sensor has magnetic component inside.

Sensitivity Adjustment of Flow

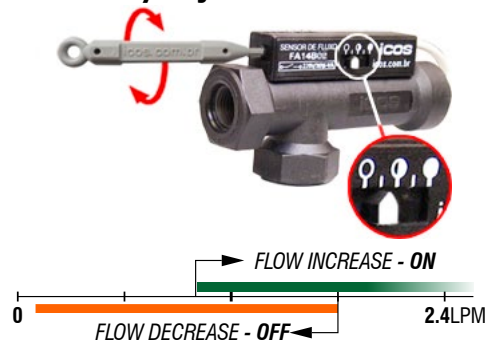

Range for sensitivity adjustment (Ref. in water)

Mounting (Important!)



Dimensions (mm) and Weight 125g

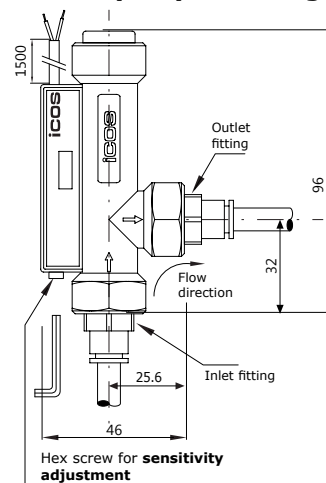

A fluid flow through the sensor causes precise displacement of magnetic piston that acts on a Reed Switch contact.

Technical specifications



Body	PPA (Polyphthalamide)
Spring	AISI 304 stainless steel
Internal clearance	8mm²
Maximum operating pressure	10bar
Operating temperature range	0°C to 100°C 140°C @1h
Inlet/outlet port	G 1/4" female
O'Ring	NBR (nitrilic rubber)
Output connection	Wire 2 x 0.14mm² x 1.5m
Enclosure rating	IP66
Electrical contact	Reed Switch

Operating Voltage	Max. Switching Power	Max. Switching Current	Peak Current
110Vac	20VA	0.2A	0.5A @20ms
220Vac	20VA	0.1A	0.5A @20ms
5Vdc	2.5W	0.5A	1A @20ms
12Vdc	5W	0.5A	1A @20ms
24Vdc*	10W	0.5A	1A @20ms

* If use contactor, RC Snubber Filter KD is required.

Included:

- O'Ring to sealing Parker - code 2-111
- K8 snubber filter to electrical installation (AC)
- Allen wrench to adjust the sensitivity
- Results of the sensitivity test (fixed in the package)

IMPORTANT!

Internal magnetic piston susceptible to retention of ferrous particles.

Installation

- In applications without excessive vibration;
- Vertical mounting with upward flow;
- Minimum distance 20mm from any ferrous surface;
- Mounting with parallel port connection and O'Ring.

Maintenance

1. Open the plug, remove the spring and clean using a brush if there is encrustation;
2. Mount the sensor again as below illustrated;
3. Test the electrical contact using an ohmmeter, moving the magnetic piston.

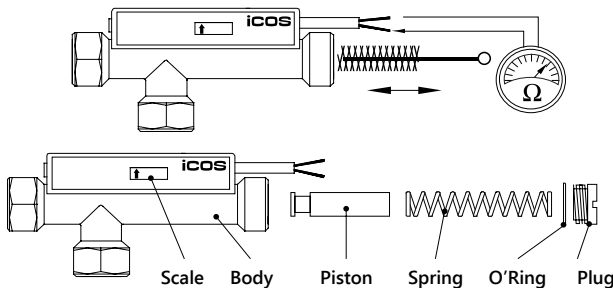

GAS (BSP) Thread: Mounting and Sealing

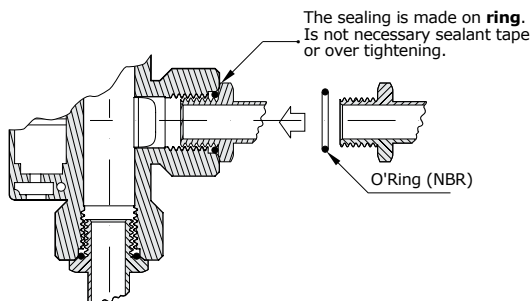

Questions? Call us BEFORE you install: +55 (15) 3032.9190

Term of Warranty

For installations according to this guide: 01 (one) year warranty.
Incorrect installation cancels the warranty - all sensors have been tested and approved.

Liquids with ferrous particles require technical analysis: the sensor has magnetic component inside.

Sensitivity Adjustment of Flow

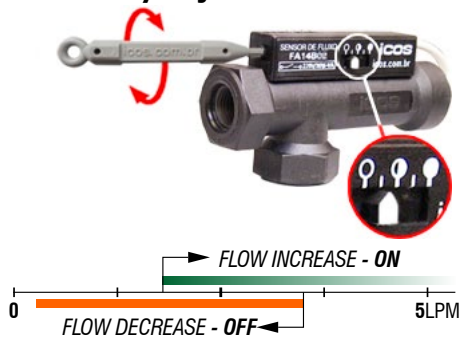

Range for sensitivity adjustment (Ref. in water)

Mounting (Important!)

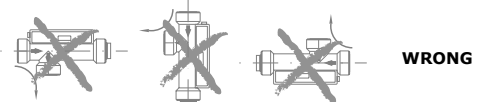

Dimensions (mm) and Weight 125g

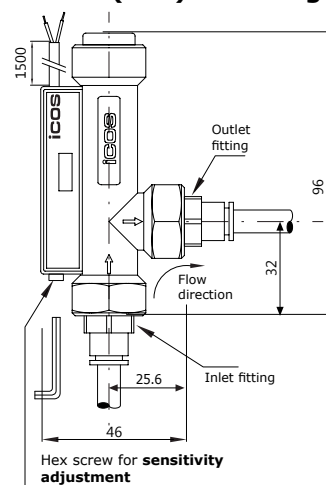

A fluid flow through the sensor causes precise displacement of magnetic piston that acts on a Reed Switch contact.

Technical specifications



Body	PPA (Polyphthalamide)
Spring	AISI 304 stainless steel
Internal clearance	8mm²
Maximum operating pressure	10bar
Operating temperature range	0°C to 100°C 140°C @1h
Inlet/outlet port	G 1/4" female
O'Ring	NBR (nitrilic rubber)
Output connection	Wire 2 x 0.14mm² x 1.5m
Enclosure rating	IP66
Electrical contact	Reed Switch

Operating Voltage	Max. Switching Power	Max. Switching Current	Peak Current
110Vac	20VA	0.2A	0.5A @20ms
220Vac	20VA	0.1A	0.5A @20ms
5Vdc	2.5W	0.5A	1A @20ms
12Vdc	5W	0.5A	1A @20ms
24Vdc*	10W	0.5A	1A @20ms

* If use contactor, RC Snubber Filter KD is required.

Included:

- O'Ring to sealing Parker - code 2-111
- K8 snubber filter to electrical installation (AC)
- Allen wrench to adjust the sensitivity
- Results of the sensitivity test (fixed in the package)

IMPORTANT!

Internal magnetic piston susceptible to retention of ferrous particles.

Installation

- In applications without excessive vibration;
- Vertical mounting with upward flow;
- Minimum distance 20mm from any ferrous surface;
- Mounting with parallel port connection and O'Ring.

Maintenance

1. Open the plug, remove the spring and clean using a brush if there is encrustation;
2. Mount the sensor again as below illustrated;
3. Test the electrical contact using an ohmmeter, moving the magnetic piston.

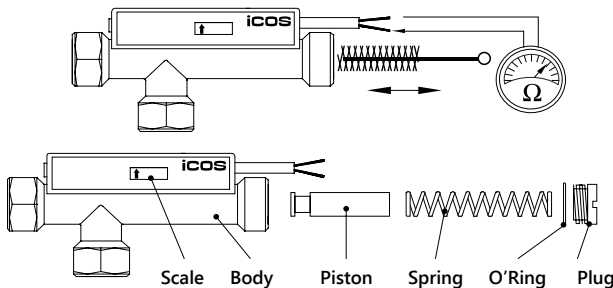

GAS (BSP) Thread: Mounting and Sealing

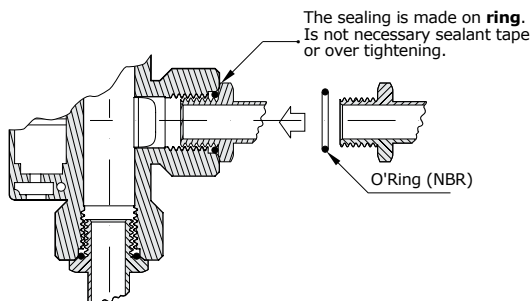

Questions? Call us BEFORE you install: +55 (15) 3032.9190

Term of Warranty

For installations according to this guide: 01 (one) year warranty.
Incorrect installation cancels the warranty - all sensors have been tested and approved.

Liquids with ferrous particles require technical analysis: the sensor has magnetic component inside.

Sensitivity Adjustment of Flow

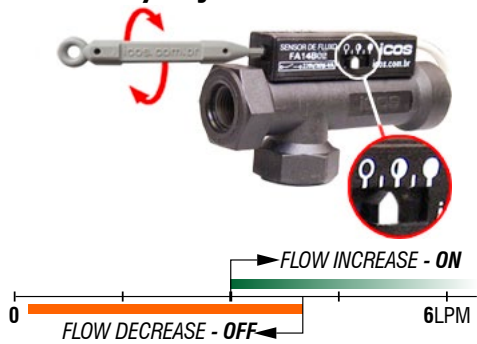

Range for sensitivity adjustment (Ref. in water)

Mounting (Important!)



Dimensions (mm) and Weight 125g

